



This appliance is filled with R-32.

Air conditioner

Installation manual

AR**NXFS*****, AR**NXWS*****, AR**NXPD*****

- Thank you for purchasing this Samsung air conditioner.
- Before operating this unit, please read this user manual carefully and retain it for future reference.



SAMSUNG

Contents

Installation	3
Safety Information on Installation	3
Preparation	8
Step 1.1 Choosing the installation location	
Step 1.2 Unpacking	
Step 1.3 Checking and preparing accessories and tools	
Step 1.4 Drilling a hole through the wall	
Step 1.5 Taping the pipes, cables, and drain hose	
Indoor Unit Installation	12
Step 2.1 Disassembling the cover panel	
Step 2.2 Disassembling the installation plate	
Step 2.3 Connecting the power and communication cables (assembly cable)	
Step 2.4 Optional: Extending the power cable	
Step 2.5 Installing and connecting the drain hose	
Step 2.6 Optional: Extending the drain hose	
Step 2.7 Optional: Changing the direction of the drain hose	
Step 2.8 Installing and connecting the assembly pipes to the refrigerant pipes (assembly pipe)	
Step 2.9 Shortening or extending the refrigerant pipes (assembly pipe)	
Step 2.10 Fixing the installation plate	
Step 2.11 Fixing the indoor unit to the installation plate	
Step 2.12 Assembling the cover panel	
Outdoor Unit Installation	21
Step 3.1 Fixing the outdoor unit in place	
Step 3.2 Connecting the power and communication cables and the refrigerant pipes	
Step 3.3 Evacuating the air	
Step 3.4 Adding refrigerant	
Step 3.5 Important information: regulation regarding the refrigerant used	
Installation Inspection	25
Step 4.1 Performing the gas leak tests	
Step 4.2 Running the Smart Install mode	
Step 4.3 Performing final check and trial operation	
Step 4.4 Display Error and Check Method	
Maintenane Procedures	29

For information on Samsung's environmental commitments and product specific regulatory obligations e.g. REACH, WEEE, Batteries, visit: samsung.com/uk/aboutsamsung/samsungelectronics/corporatecitizenship/data_corner.html

Safety Information on Installation

Carefully follow the precautions listed below because they are essential to guarantee the safety of both the air conditioner and the workers.

- Always disconnect the air conditioner from the power supply before servicing it or accessing its internal components.
- Verify that installation and testing operations are performed by qualified personnel.
- Verify that the air conditioner is not installed in an easily accessible area.

General information

- Carefully read the content of this manual before installing the air conditioner and store the manual in a safe place in order to be able to use it as reference after installation.
- For maximum safety, installers should always carefully read the following warnings.
- Store the operation and installation manual in a safe location and remember to hand it over to the new owner if the air conditioner is sold or transferred.
- This manual explains how to install an indoor unit with a split system with two SAMSUNG units. The use of other types of units with different control systems may damage the units and invalidate the warranty. The manufacturer shall not be responsible for damages arising from the use of non compliant units.
- The manufacturer shall not be responsible for damage originating from unauthorised changes or the improper connection of electric and requirements set forth in the "Operating limits" table, included in the manual, shall immediately invalidate the warranty.
- The air conditioner should be used only for the applications for which it has been designed: the indoor unit is not suitable to be installed in areas used for laundry.
- Do not use the units if damaged. If problems occur, switch the unit off and disconnect it from the power supply.
- In order to help prevent electric shocks, fires or injuries, always stop the unit, disable the protection switch and contact SAMSUNG's technical support if the unit produces smoke, if the power cable is hot or damaged or if the unit is very noisy.
- Always remember to inspect the unit, electric

connections, refrigerant tubes and protections regularly. These operations should be performed by qualified personnel only.

- The unit contains moving parts, which should always be kept out of the reach of children.
- Do not attempt to repair, move, alter or reinstall the unit. If performed by unauthorised personnel, these operations may cause electric shocks or fires.
- Do not place containers with liquids or other objects on the unit.
- All the materials used for the manufacture and packaging of the air conditioner are recyclable.
- The packing material and exhaust batteries of the remote control (optional) must be disposed of in accordance with current laws.
- The air conditioner contains a refrigerant that has to be disposed of as special waste. At the end of its life cycle, the air conditioner must be disposed of in authorised centres or returned to the retailer so that it can be disposed of correctly and safely.
- Do not use means to accelerate the defrost operation or to clean, other than those recommended by Samsung.
- Do not pierce or burn.
- Be aware that refrigerants may not contain an odour.

Installation of the product

- **IMPORTANT:** When installing the unit, always remember to connect first the refrigerant tubes, then the electrical lines. Always disassemble the electric lines before the refrigerant tubes.
- Upon receipt, inspect the product to verify that it has not been damaged during transport. If the product appears damaged, **DO NOT INSTALL** it and immediately report the damage to the carrier or retailer (if the installer or the authorised technician has collected the material from the retailer.)
- After completing the installation, always carry out a functional test and provide the instructions on how to operate the air conditioner to the user.

- Do not use the air conditioner in environments with hazardous substances or close to equipment that release free flames to avoid the occurrence of fires, explosions or injuries.
 - Our units must be installed in compliance with the spaces indicated in the installation manual to ensure either accessibility from both sides or ability to perform routine maintenance and repairs. The units' components must be accessible and that can be disassembled in conditions of complete safety either for people or things. For this reason, where it is not observed as indicated into the Installation Manual, the cost necessary to reach and repair the unit (in safety, as required by current regulations in force) with slings, trucks, scaffolding or any other means of elevation won't be considered in-warranty and will be charged to end user.
 - The outdoor unit shall be installed in an open space that is always ventilated.
 - The local gas regulations shall be observed.
 - To handle, purge, and dispose the refrigerant, or break into the refrigerant circuit, the worker should have a certificate from an industry-accredited authority.
 - Do not install the indoor unit in the following areas:
 - Area filled with minerals, splashed oil, or steam. It will deteriorate plastic parts, causing failure or leakage.
 - Area that is close to heat sources.
 - Area that produces substances such as sulfuric gas, chlorine gas, acid, and alkali. It may cause corrosion of the pipings and brazed joints.
 - Area that can cause leakage of combustible gas and suspension of carbon fibers, flammable dust, or volatile flammables.
 - Area where refrigerant leaks and settles.
 - Area where animals may urinate on the product. Ammonia may be generated.
 - Do not use the indoor unit for preservation of food items, plants, equipment, and art works. This may cause deterioration of their quality.
 - Do not install the indoor unit if it has any drainage problem.
- Make sure to install the product behind a structure (such as building) that can block sea breeze.
 - Even when it is inevitable to install the product in seashore, make sure that product is not directly exposed to sea breeze by installing a protection wall.
2. Consider that the salinity particles clinging to the external panels should be sufficiently washed out.
 3. Because the residual water at the bottom of the outdoor unit significantly promotes corrosion, make sure that the slope does not disturb drainage.
 - Keep the floor level so that rain does not accumulate.
 - Be careful not to block the drain hole due to foreign substance
 4. When product is installed in seashore, periodically clean it with water to remove attached salinity.
 5. Make sure to install the product in a place that provides smooth water drainage. Especially, ensure that the base part has good drainage.
 6. If the product is damaged during the installation or maintenance, make sure to repair it.
 7. Check the condition of the product periodically.
 - Check the installation site every 3 months and perform anti-corrosion treatment such as R-Pro supplied by SAMSUNG (Code : MOK-220SA) or commercial water repellent grease and wax, etc., based on the product condition.
 - When the product is to be shut down for a long period of time, such as off-peak hours, take appropriate measures like covering the product.
 8. If the product installed within 500m of seashore, special anti-corrosion treatment is required.
* Please contact your local SAMSUNG representative for further details.

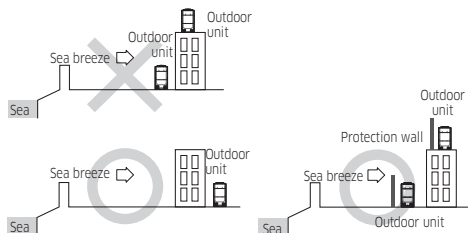

Installation Guide at the seashore

- Make sure to follow below guides when installing at the seashore.
1. Do not install the product in a place where it is directly exposed to sea water and sea breeze.
- Protection wall should be constructed with a solid material that can block the sea breeze and the height and width of the wall should be 1.5 times larger than the size of the outdoor unit. (You must secure more than 700mm of space between the protection wall and the

outdoor unit for air circulation.)

- For the multi system, this indoor unit can be connected to an R-32 outdoor unit.

Check the type of refrigerant in the outdoor unit.

- Because your air conditioner contains R-32 refrigerant, make sure that it is installed, operated, and stored in a room whose floor area is larger than the minimum required floor area specified in the following table:

Wall-mounted type	
m (kg)	A(m ²)
≤ 1.842	No requirement
1.843	4.45
1.9	4.58
2.0	4.83
2.2	5.31
2.4	5.79
2.6	6.39
2.8	7.41
3.0	8.51

- m : Total refrigerant charge in the system
- A : Minimum required floor area

- **IMPORTANT:** it's mandatory to consider either the table above or taking into consideration the local law regarding the minimum living space of the premises.
- Minimum installation height of indoor unit is 0.6 m for floor mounted, 1.8 m for wall, 2.2 m for ceiling.

Installation of the outdoor unit

- While in installation or relocation of the product, do not mix the refrigerant with other gases including air or unspecified refrigerant. Failure to do so may cause pressure increase to result in rupture or injury.
- Do not cut or burn the refrigerant container or pipings.
- Use clean parts such as manifold gauge, vacuum pump, and charging hose for the refrigerant.
- Installation must be carried out by qualified personnel for handling the refrigerant. Additionally, reference the

regulations and laws.

- Be careful not to let foreign substances (lubricating oil, refrigerant, water, etc.) enter the pipings. The application of oil or refrigerant deteriorates the pipings to result in drain leakage. For storage, securely seal their openings.
- When mechanical ventilation is required, ventilation openings shall be kept clear of obstruction.
- For disposal of the product, follow the local laws and regulations.
- Do not work in a confined place.
- The work area shall be blocked.
- The refrigerant pipings shall be installed in the position where there are no substances that may result in corrosion.
- The following checks shall be performed for installation:
 - The charging amount depends on the room size.
 - The ventilation devices and outlets are operating normally and are not obstructed.
 - Markings and signs on the equipment shall be visible and legible.
- Upon leakage of the refrigerant, ventilate the room. When the leaked refrigerant is exposed to flame, it may cause generation of toxic gases.
- Make sure that the work area is safe from flammable substances.
- To purge air in the refrigerant, be sure to use a vacuum pump.
- Note that the refrigerant has no odour.
- The units are not explosion proof so they must be installed with no risk of explosion.
- This product contains fluorinated gases that contribute to global greenhouse effect. Accordingly, do not vent gases into the atmosphere.
- Because the working pressure for R-32 is 1.6 times higher than that for R-22, use exclusive pipings and tools specified. In case of replacing an R-22 model with an R-32 model, be sure to replace the conventional pipings and flare nuts with exclusive ones.
- The models that use the refrigerant R-32 have a different thread diameter for the charging port to prevent charging failure. Therefore, check its diameter (1/2 inch) in advance.
- Servicing shall be performed as recommended by the

manufacturer. In case other skilled persons are joined for servicing, it shall be carried out under supervision of the person who is competent in handling flammable refrigerants.

- For servicing the units containing flammable refrigerants, safety checks are required to minimise the risk of ignition.
- Servicing shall be performed following the controlled procedure to minimize the risk of flammable refrigerant or gases.
- Do not install where there is a risk of combustible gas leakage.
- Do not place heat sources.
- Be cautious not to generate a spark as follows:
 - Do not remove the fuses with power on.
 - Do not disconnect the power plug from the wall outlet with power on.
 - It is recommended to locate the outlet in a high position. Place the cords so that they are not tangled.
- If the indoor unit is not R-32 compatible, an error signal appears and the unit will not operate.
- After installation, check for leakage. Toxic gas may be generated and if it comes into contact with an ignition source such as fan heater, stove, and cooker. cylinders, make sure that only the refrigerant recovery cylinders are used.

Preparation of fire extinguisher

- If a hot work is to be done, an appropriate fire extinguishing equipment should have been available.
- A dry powder or CO₂ fire extinguisher shall be equipped near the charging area.

Ignition sources free

- Make sure to store the units in a place without continuously operating ignition sources (for example, open flames, an operating gas appliance or an operating electric heater).
- The service engineers shall not use any ignition sources with the risk of fire or explosion.
- Potential ignition sources shall be kept away from the work area where the flammable refrigerant can possibly be released to the surrounding.

- The work area should be checked to ensure that there are no flammable hazards or ignition risks. The “No Smoking” sign shall be attached.
- Under no circumstances shall potential sources of ignition be used while in detection of leakage.
- Make sure that the seals or sealing materials have not degraded.
- Safe parts are the ones with which the worker can work in a flammable atmosphere. Other parts may result in ignition due to leakage.
- Replace components only with parts specified by Samsung. Other parts may result in the ignition of refrigerant in the atmosphere from a leak.

Area ventilation

- Make sure that the work area is well ventilated before performing a hot work.
- Ventilation shall be made even during the work.
- The ventilation should safely disperse any released gases and preferably expel them into the atmosphere.
- Ventilation shall be made even during the work.

Leakage detection methods

- The leakage detector shall be calibrated in a refrigerant-free area.
- Make sure that the detector is not a potential source of ignition.
- The leakage detector shall be set to the LFL (lower flammability limit).
- The use of detergents containing chlorine shall be avoided for cleaning because the chlorine may react with the refrigerant and corrode the pipings.
- If leakage is suspected, naked flames shall be removed.
- If a leakage is found while in brazing, the entire refrigerant shall be recovered from the product or isolated (e.g. using shut-off valves). It shall not be directly released to the environment. Oxygen free nitrogen (OFN) shall be used for purging the system before and during the brazing process.
- The work area shall be checked with an appropriate refrigerant detector before and during work.
- Ensure that the leakage detector is appropriate for use with flammable refrigerants.

Labelling

- The parts shall be labelled to ensure that they have been decommissioned and emptied of refrigerant.
- The labels shall be dated.
- Make sure that the labels are affixed on the system to notify it contains flammable refrigerant.

Recovery

- When removing refrigerant from the system for servicing or decommissioning, it is recommended to remove the entire refrigerant.
- When transferring refrigerant into cylinders, make sure that only the refrigerant recovery cylinders are used.
- All cylinders used for the recovered refrigerant shall be labelled.
- Cylinders shall be equipped with pressure relief valves and shut-off valves in a proper order.
- Empty recovery cylinders shall be evacuated and cooled before recovery.
- The recovery system shall operate normally according to the specified instructions and shall be suitable for refrigerant recovery.
- In addition, the calibration scales shall operate normally.
- Hoses shall be equipped with leak-free disconnect couplings.
- Before starting the recovery, check for the status of the recovery system and sealing state. Consult with the manufacturer if suspected.
- The recovered refrigerant shall be returned to the supplier in the correct recovery cylinders with the Waste Transfer Note attached.
- Do not mix refrigerants in the recovery units or cylinders.
- If compressors or compressor oils are to be removed, make sure that they have been evacuated to the acceptable level to ensure that flammable refrigerant does not remain in the lubricant.
- The evacuation process shall be performed before sending the compressor to the suppliers.
- Only the electrical heating to the compressor body is allowed to accelerate the process.
- Oil shall be drained safely from the system.

- For installation with handling the refrigerant (R-32), use dedicated tools and piping materials. Because the pressure of the refrigerant, R-32 is approximately 1.6 times higher than that of R-22, failure to use the dedicated tools and piping materials may cause rupture or injury. Furthermore, it may cause serious accidents such as water leakage, electric shock, or fire.
- Never install a motor-driven equipment to prevent ignition.

Power supply line, fuse, or circuit breaker

- Always make sure that the power supply is compliant with current safety standards. Always install the air conditioner in compliance with current local safety standards.
- Always verify that a suitable grounding connection is available.
- Verify that the voltage and frequency of the power supply comply with the specifications and that the installed power is sufficient to ensure the operation of any other domestic appliance connected to the same electric lines.
- Always verify that the cut-off and protection switches are suitably dimensioned.
- Verify that the air conditioner is connected to the power supply in accordance with the instructions provided in the wiring diagram included in the manual.
- Always verify that electric connections (cable entry, section of leads, protections..) are compliant with the electric specifications and with the instructions provided in the wiring scheme. Always verify that all connections comply with the standards applicable to the installation of air conditioners.
- Be sure not to perform power cable modification, extension wiring, and multiple wire connection.
 - It may cause electric shock or fire due to poor connection, poor insulation, or current limit override.
 - When extension wiring is required due to power line damage, refer to "Step 2.4 Optional: Extending the power cable" in the installation manual.

Preparation

Step 1.1 Choosing the installation location

Overview of installation location requirements

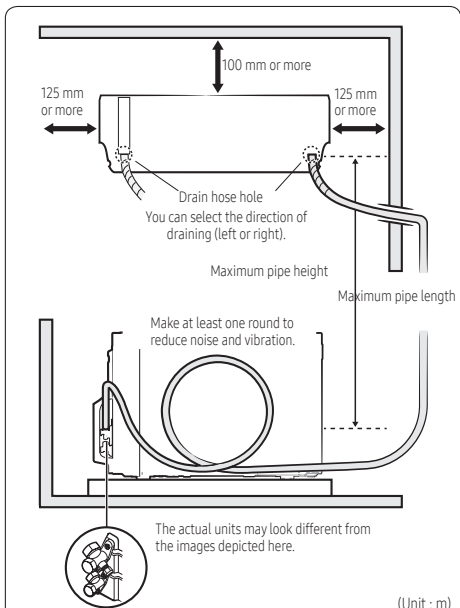

(Unit : m)

Model	Pipe length			Pipe height
	Minimum	Maximum	Standard for factory charge	Maximum charge
09/12***	3	15	5	8

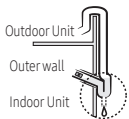

Make a U-trap (A) on the pipe (which is connected to the indoor unit) at outer wall and cut the bottom part of the insulation (about 10 mm) to prevent rainwater from getting inside through the insulation.

⚠ CAUTION

- Comply with the length and height limits described in the figure above.
- For the product that uses the R-32 refrigerant, Install the indoor unit on the wall 1.8 m or higher from the floor.

Minimum clearances for the outdoor unit

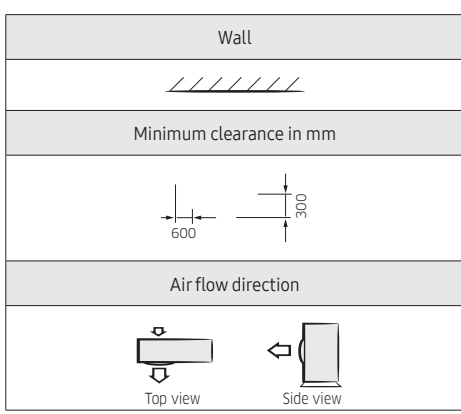

When installing 1 outdoor unit (6 cases)

(Unit: mm)

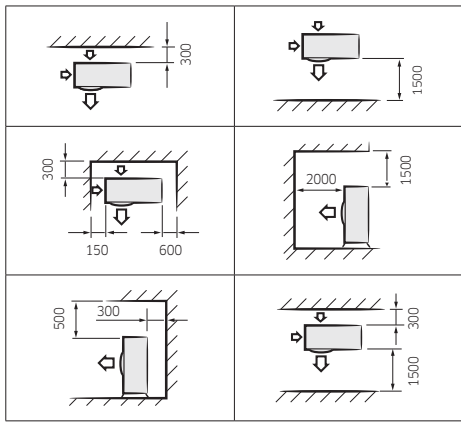

When installing more than 1 outdoor unit (5 cases)

(Unit: mm)

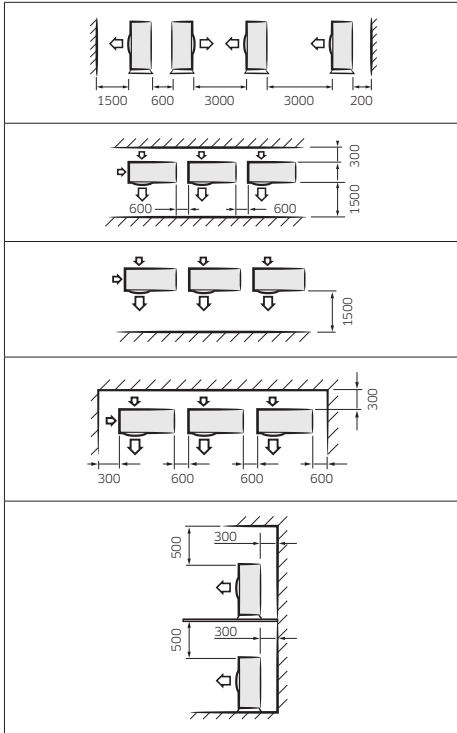

⚠ CAUTION

- If the outdoor unit is installed with any insufficient clearance, it may generate sound and affect the whole product.
- Be sure to install the outdoor unit in a level place where its vibration does not affect the whole product.

Step 1.2 Unpacking

Unpacking the indoor unit

- 1 Open the indoor unit package.
- 2 Remove the left and right cushions.
- 3 Pull out the unit from the package.









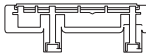

Unpacking the outdoor unit

- 1 Remove the package.
- 2 Remove the top cushion.
- 3 Pull out the unit from the bottom cushion.













Step 1.3 Checking and preparing accessories and tools

Accessories

Accessories in the indoor unit package

Installation plate (1) **09/12*****	Remote control (1)
	
Remote control battery (2)	User Manual (1)
	
Installation Manual (1)	Cap screw (2)
	
Guide Right (1)	Guide Left (1)
	
M4 x 16 Tapped Screws (2)	Remote Control Holder (1)
	

Optional accessories

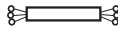
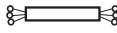
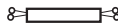
Insulated assembly pipe, Ø 6.35 mm (1)	Insulated assembly pipe, Ø 9.52 mm (1) **09/12*****
	
Pipe clamp B (3)	Pipe clamp A (3)
	
Drain Hose, 2 m long (1)	Foam Insulation (1)
	
Vinyl tape (2)	PE T3 foam tube insulation (1)
	
Putty 100 g (1)	Drain plug (1)
	
M4 x 25 tapped screw (6)	Cement nail (6)
	
3-wire Power Cable (1)	3-wire Assembly Cable (1)
	
2-wire Assembly Cable (1)	
	

Accessories in the outdoor unit package

Rubber leg (4)

NOTE

- A flare nut is attached to the end of each pipe of an evaporator or a service port. Use flare nuts when connecting the pipes.
- Wire assembly cables are optional. If they are not supplied, use standard cables.
- The drain plug and the rubber legs are included only when the air conditioner is supplied without assembly pipes.
- If these accessories are supplied, they are in the accessory package or outdoor unit package.

Tools

General tools

- Vacuum pump (Backward flowing prevention)
- Manifold gauge
- Stud finder
- Torque wrench
- Pipe cutter
- Reamer
- Pipe bender
- Spirit level
- Screwdriver
- Spanner
- Drill
- L-wrench
- Measuring tape

Tools for test operation

- Thermometer
- Resistance meter
- Electroscopes

Step 1.4 Drilling a hole through the wall

Before fixing the installation plate to a wall and then fixing the indoor unit to the installation plate, a window frame, or a gypsum board, you must determine the position of a hole (with 65 mm inner diameter) through which the pipe bundle (consisting of power and communication cables, refrigerant pipes, and drain hose) will pass and then drill that hole.

- 1 Determine the position of a 65 mm hole in consideration of the possible directions of the pipe bundle and the minimum distances between the hole and the installation plate.

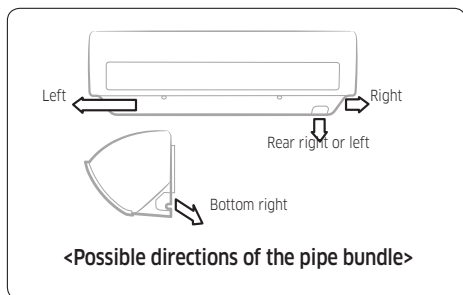

CAUTION

- If changing the pipe direction from left to right, do not drastically bent it but slowly turn it in the opposite direction as shown. Otherwise, the pipe may be damaged in the process.

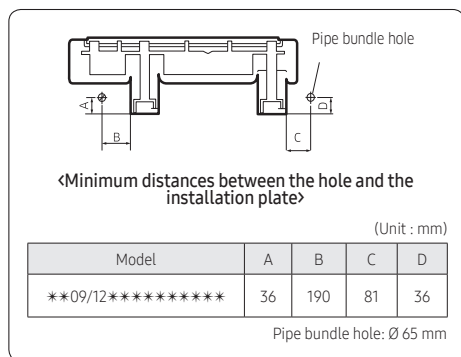

- 2 Drill the hole.

CAUTION

- Be sure to drill only one hole.
- Make sure that the hole slants downwards so that the drain hose slants downwards to drain water well.

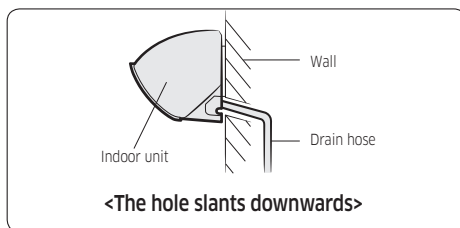

Step 1.5 Taping the pipes, cables, and drain hose

- 1 Wrap foam insulation on parts without insulation on the ends of the refrigerant pipes, as shown in the figure. This wrapping minimises condensation problem.

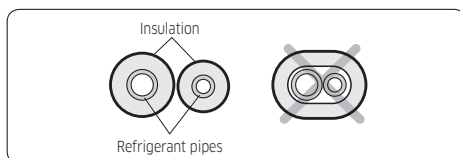

- 2 Wind the refrigerant pipes, power cable, communication cable and drain hose with vinyl tape to make a pipe bundle.

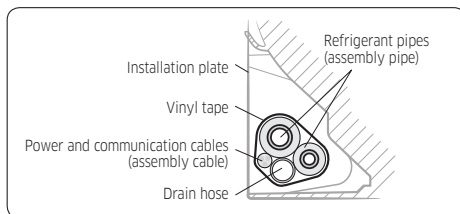

Indoor Unit Installation



Please scan this QR code for detail video of indoor unit installation.

Step 2.1 Disassembling the cover panel

1 Remove the cap screws, then the screws.

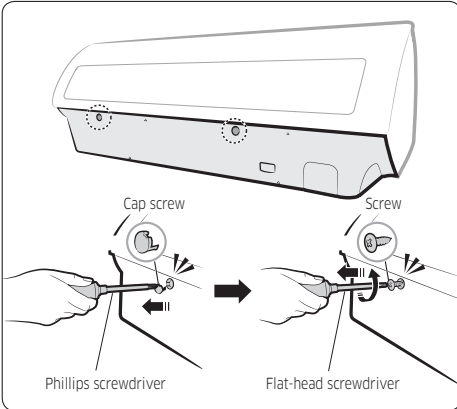

2 Unlock the side hooks (1, 2), then centre hooks (3). Then unlock the bottom hooks (4) to pull out the cover panel.

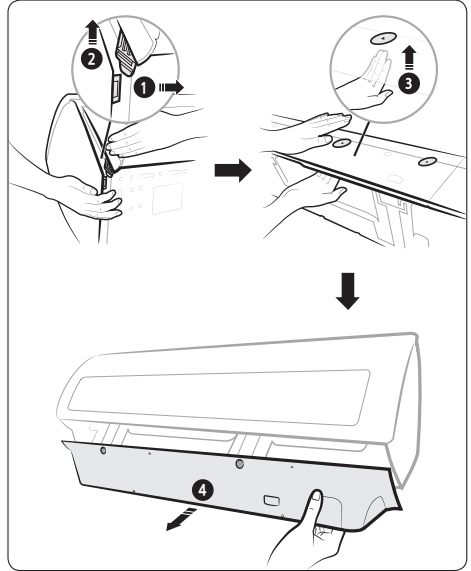
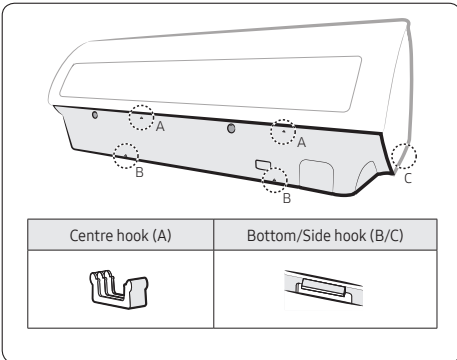

Step 2.2 Disassembling the installation plate

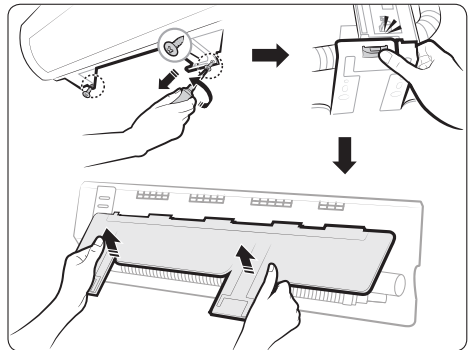

Step 2.3 Connecting the Power and communication cables (assembly cable)

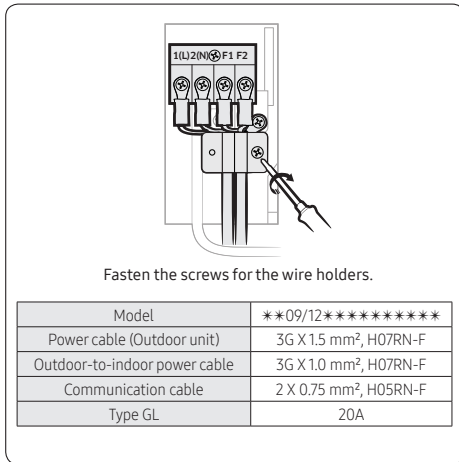
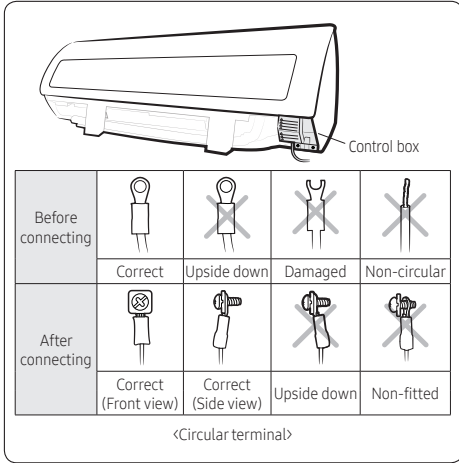

- When performing electrical and earthing works, be sure to comply with the 'technical standards of electrical installations' and the 'wiring regulations' in the local regulations.
- Tighten the terminal block screw to 1.2-1.8 N•m (1.2-1.8 kgf•cm).

NOTE

- Each wire is labelled with the corresponding terminal number.
- Use shield cable (Category 5; less than 50pF/m) for noisy environmental site.
- Power supply cords of parts of appliances for outdoor use shall not be lighter than polychloroprene sheathed flexible cord. (Code designation IEC: 60245 IEC66/CENELEC: H07RN-F, IEC: 60245 IEC57 CENELEC: H05RN-F, IEC: 60227 IEC53: H05VV-F)
- Power & Communication cable shall not exceed 30m.

CAUTION

- For the terminal block wiring, use a wire with a ring terminal socket only. Regular wires without a ring terminal socket may become a hazard due to overheating of the electrical contact during installation.
- If you need to extend the pipe, be sure to extend the cable, too.

Model	Cable (Maximum)
****NXFS*****	30m
****NXWS*****	
****NXPD*****	





- Do not connect two or more different cables to extend the length. This connection may cause fire.
- Each circular terminal must match the size of its corresponding screw in the terminal block.
- After connecting the cables, make sure that terminal numbers on the indoor and outdoor units match.
- Ensure that power and communication cables are separated, they must not be in the same cable.
- For the product that uses the R-32 refrigerant, be cautious not to generate a spark by keeping the following requirements:
 - Do not remove the fuses with power on.
 - Do not disconnect the power plug from the wall outlet with power on.
 - It is recommended to locate the outlet in a high position. Place the cords so that they are not tangled.

WARNING

- Connect the wires firmly so that wires cannot be pulled out easily. (If they are loose, it could cause burn-out of the wires.)

Step 2.4 Optional: Extending the power cable

1 Prepare the following tools.

Tools	Spec	Shape
Crimping pliers	MH-14	
Connection sleeve (mm)	20xØ6.5 (HxOD)	
Insulation tape	Width 19 mm	
Contraction tube (mm)	70xØ8.0 (LxOD)	

2 As shown in the figure, peel off the shields from the rubber or wire of the power cable.

- Peel off 20 mm of cable shields from the preinstalled tube.

CAUTION

- For information about the power cable specifications for indoor and outdoor units, refer to the installation manual.
- After peeling off cable wires from the preinstalled tube, insert a contraction tube.

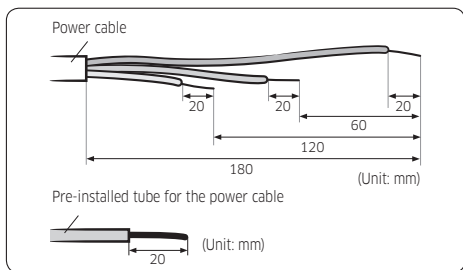

3 Insert both sides of core wire of the power cable into the connection sleeve.

- Method 1: Push the core wire into the sleeve from both sides.
- Method 2: Twist the wire cores together and push it into the sleeve.

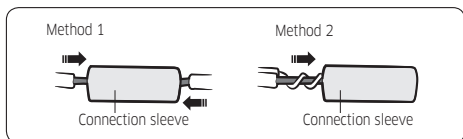

4 Using a crimping tool, compress the two points and flip it over and compress another two points in the same location.

- The compression dimension should be 8.0.

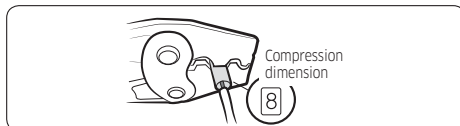

- After compressing it, pull both sides of the wire to make sure it is firmly pressed.

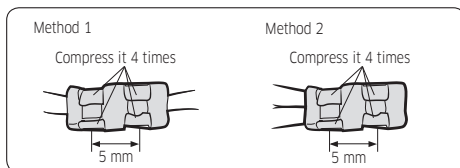

5 Wrap it with the insulation tape twice or more and position your contraction tube in the middle of the insulation tape. Three or more layers of insulation are required.

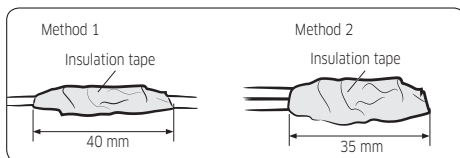

6 Apply heat to the contraction tube to contract it.

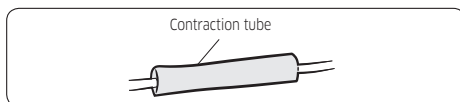

7 After tube contraction work is completed, wrap it with the insulation tape to finish.

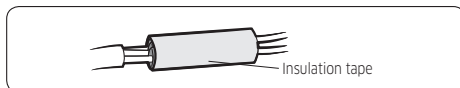

CAUTION

- Make sure that the connection parts are not exposed to outside.
- Be sure to use insulation tape and a contraction tube made of approved reinforced insulating materials that have the same level of withstand voltage with the power cable. (Comply with the local regulations on extensions.)

⚠ WARNING

- In case of extending the electric wire, please DO NOT use a round-shaped pressing socket.
- Incomplete wire connections can cause electric shock or a fire.

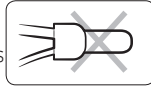

⚠ CAUTION

- Make sure that the indoor unit is in upright position when you pour water to check for leakage. Make sure that the water does not overflow onto the electrical part.
- If the diameter of the connection hose is smaller than the product's drain hose, water leakage may occur.
- Inadequate installation may cause water leakage.
- If the drain hose is routed inside the room, insulate the hose so that dripping condensation does not damage the furniture or floors.
- Do not box in or cover the drain hose connection. Drain hose connection must be easily accessible and serviceable.

Step 2.5 Installing and connecting the drain hose

1 Install the drain hose.

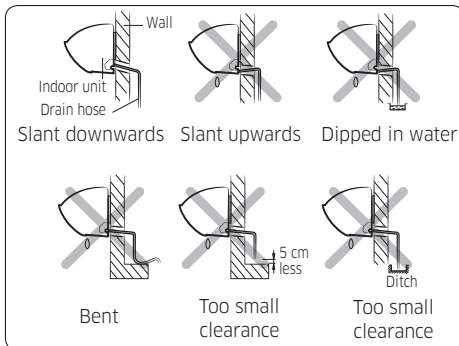
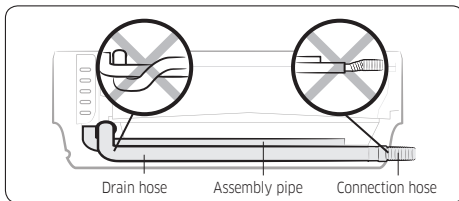

2 Pour water into the drain pan. Check whether the hose is well drained.

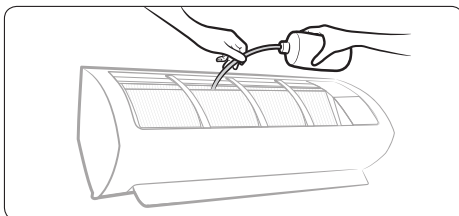

Step 2.6 Optional: Extending the drain hose

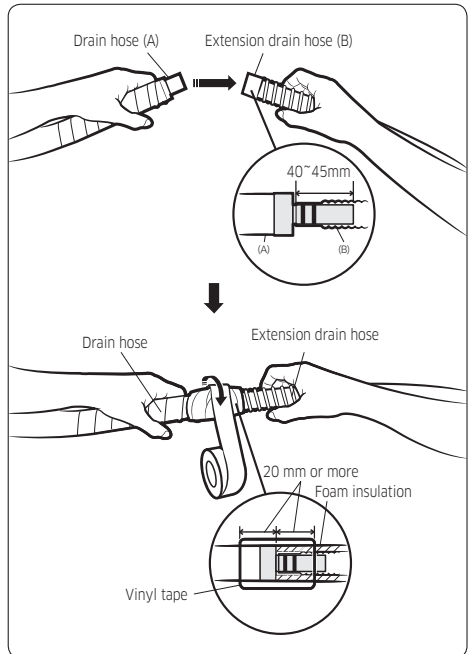

Step 2.7 Optional: Changing the direction of the drain hose

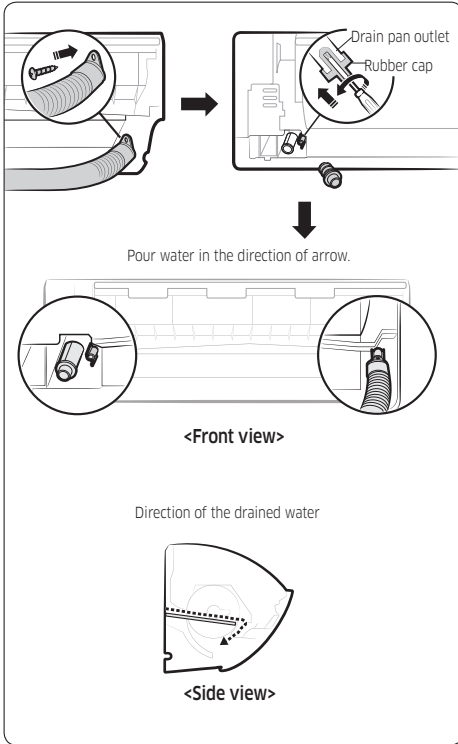

⚠ CAUTION

- Make sure that the indoor unit is in upright position when you pour water to check for leakage. Make sure that the water does not overflow onto the electrical part.

Step 2.8 Installing and connecting the assembly pipes to the refrigerant pipes (assembly pipe)

Connect indoor and outdoor units with field-supplied copper pipes by means of flare connections. Use insulated seamless refrigeration grade pipe only, (Cu DHP type according to ISO1337), degreased and deoxidized, suitable for operating pressures of at least 4200 kPa and for burst pressure of at least 20700 kPa. Under no circumstances must sanitary type copper pipe be used.

There are 2 refrigerant pipes of different diameters:

- The smaller one is for the liquid refrigerant
- The larger one is for the gas refrigerant

A short liquid refrigerant pipe and a short gas refrigerant pipe are already fitted to the air conditioner. The connection procedure for the refrigerant pipes varies according to the exit position of each pipe when facing the wall:

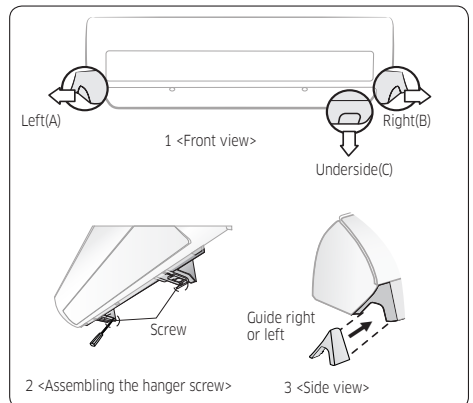

- 1 Cut out the appropriate knock-out piece (A, B, C) on the rear of the indoor unit unless you connect the pipe directly from the rear.
- 2 Smooth the cut edges.

- 3 Remove the protection caps of the pipes and connect the assembly pipe to each pipe. Tighten the nuts first with your hands, and then with a torque wrench, applying the following torque:

Outer diameter (mm)	Torque (N•m)	Torque (kgf•cm)
ø 6.35	14 to 18	140 to 180
ø 9.52	34 to 42	350 to 430
ø 12.70	49 to 61	500 to 620
ø 15.88	68 to 82	690 to 830

NOTE

- If you want to shorten or extend the pipes, see Step 2.9 Shortening or extending the refrigerant pipes (assembly pipe) on page 17.
 - Tighten the nuts to the specified torques. If overtightened, the nuts could be broken so refrigerant may leak.
- 4 Cut off the remaining foam insulation.
- 5 If necessary, bend the pipe to fit along the bottom of the indoor unit. Then pull it out through the appropriate hole.
- The pipe should not project from the rear of the indoor unit.
 - The bending radius should be 100 mm or more.
- 6 Pass the pipe through the hole in the wall.
- 7 Fix the indoor unit on the wall. Pass the cables, pipes and hose through the knock-out hole which would be connected to the outdoor unit.
- 8 Use 2 screws to fix the indoor unit as shown in the picture 2.
- 9 Assemble the Guide into the position of A or B as shown in the picture 3.

NOTE

- The pipe will be insulated and fixed permanently into position after finishing the installation and the gas leak test. For further details, see Step 4.1 Performing the gas leak tests on page 25.

CAUTION

- Tighten the flare nut with a torque wrench according to specified method. If the flare nut is over-tightened, the flare may break and cause refrigerant gas leakage.
- Do not box in or cover the pipe connection. All refrigerant pipe connection must be easily accessible and serviceable.

Step 2.9 Shortening or extending the refrigerant pipes (assembly pipe)

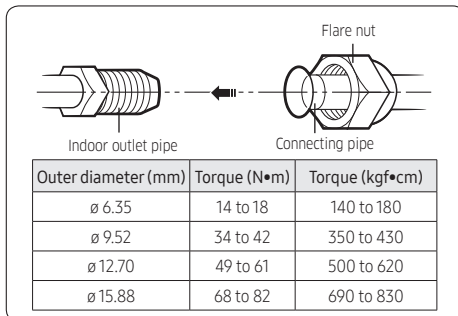
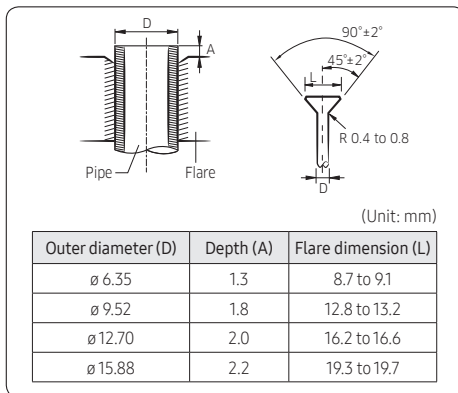
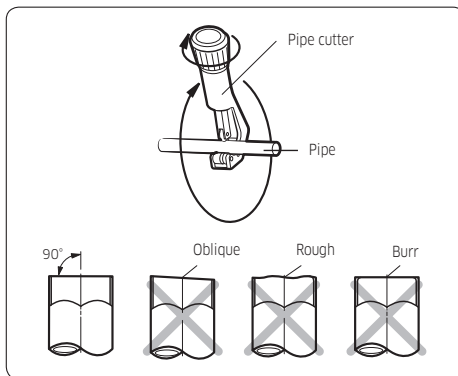

⚠ CAUTION

- Keep the piping length at a minimum to minimize the additional refrigerant charge due to piping extension. (Maximum allowable piping length: 15 m)
- When connecting the pipes, make sure that surrounding objects do not interfere with or contact them to prevent refrigerant leakage due to physical damage.
- Make sure that the spaces where the refrigerant pipes are installed comply with national gas regulations.
- Be sure to perform works such as additional refrigerant charging and pipe welding under the conditions of good ventilation.
- Be sure to perform welding and piping works for mechanical connections under the conditions that the refrigerant does not circulate.
- When reconnecting the pipes, make sure to perform flared-jointing newly to prevent refrigerant leakage.
- When working on the refrigerant pipes and the flexible refrigerant connectors, be careful that they are not damaged physically by surrounding objects.
- If you need a pipe longer than specified in piping codes and standards, you must add refrigerant to the pipe. Otherwise, the indoor unit may freeze.
- While removing burrs, put the pipe face down to make sure that the burrs do not get in to the pipe.

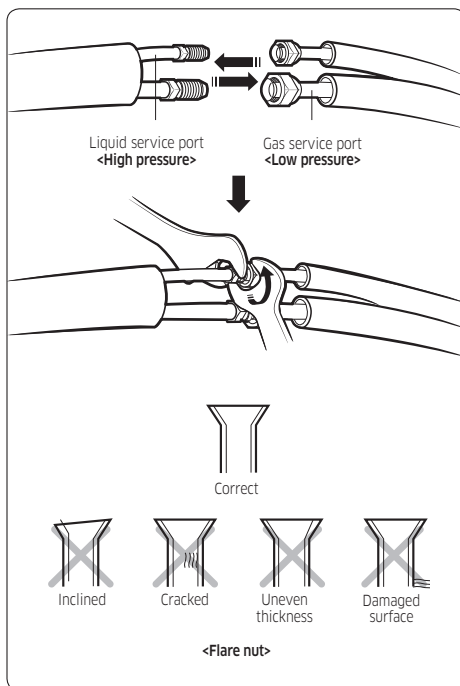

📖 NOTE

- Excessive torque may cause gas leakage. When extending the pipe with welding or brazing, ensure that nitrogen is used during the welding or brazing process. The joint must be accessible and serviceable.

⚠ CAUTION

- Tighten the flare nut at the specified torque. If the flare nut is over-tightened, it may break to cause leakage of refrigerant gas.

Step 2.10 Fixing the installation plate

You can install the indoor unit on a wall, window frame, or gypsum board.

WARNING

- Make sure that the wall, window frame, or gypsum board can withstand the weight of the indoor unit. If you install the indoor unit in a place where it is not strong enough to withstand the unit's weight, the unit could fall and cause injury.

When fixing the indoor unit on a wall

Fix the installation plate to the wall giving attention to the weight of the indoor unit.

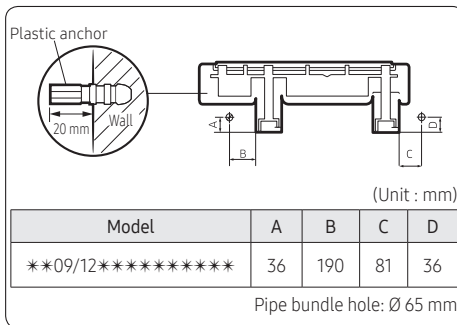

NOTE

- If you mount the plate to a concrete wall using plastic anchors, make sure that gaps between the wall and the plate, created by projected anchor, is less than 20 mm.

When fixing the indoor unit on a window frame

- 1 Determine the positions of the wooden uprights to be attached to the window frame.
- 2 Attach the wooden uprights to the window frame giving attention to the weight of the indoor unit.
- 3 Attach the installation plate to the wooden upright using tapping screws.

When fixing the indoor unit on a gypsum board

- 1 Use stud finder to find out locations of the studs.
- 2 Fix the plate hanger on two studs.

CAUTION

- If you fix the indoor unit on a gypsum board, use only specified anchor bolts on reference positions. Otherwise, the gypsum surrounding the joints may crumble over time and cause the screws to be loosened and stripped. This may lead to physical injury or equipment damage.
- Search for other spots if there are less than two studs, or the distance between the studs are different from the plate hanger.
- Fix the installation plate without inclining to one side.

Step 2.11 Fixing the indoor unit to the installation plate

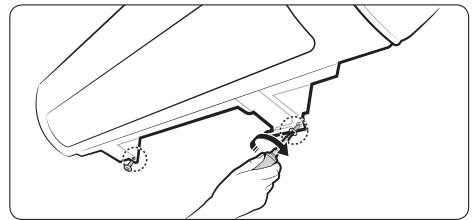

CAUTION

- Make sure that the pipe bundle does not move when you install the indoor unit onto the installation plate.

Step 2.12 Assembling the cover panel

- 1 Lock the side hooks (D), then centre hooks (B). Then lock the bottom hooks (C) to engage the cover panel in place.
- 2 Fasten the screw (A-1), then assemble the cap screws (A-2).

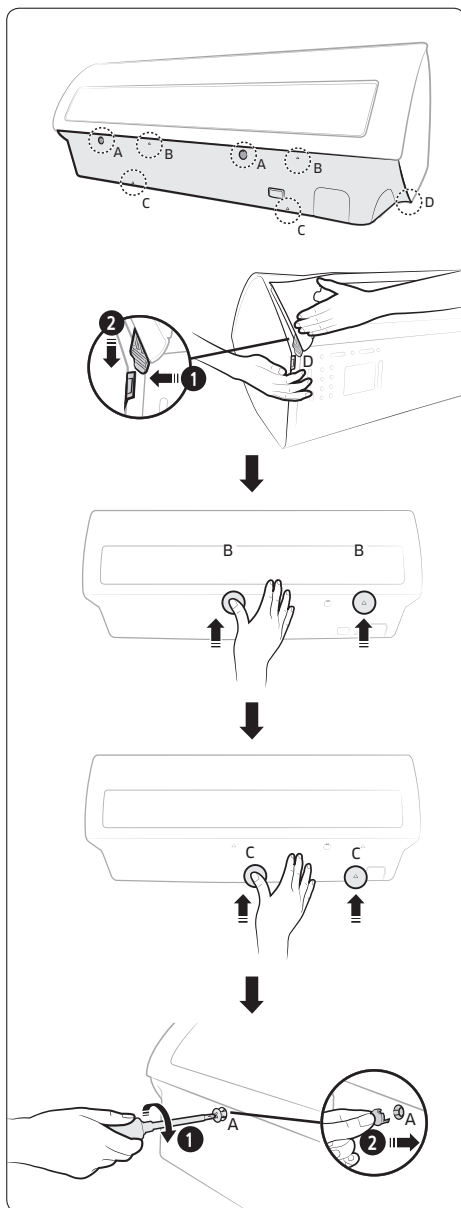

Outdoor Unit Installation

Step 3.1 Fixing the outdoor unit in place

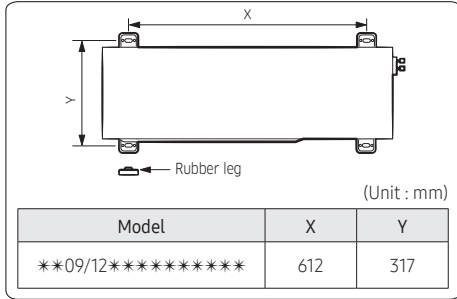

- 1 Place the outdoor unit as directed on the top of the unit to let the discharged air out properly.
- 2 Fix the outdoor unit in level to an appropriate support using anchor bolts.

NOTE

- Secure the rubber legs to help prevent the generation of noise and vibration.
- If the outdoor unit is exposed to strong winds, install shield plates around the outdoor unit so that the fan can operate correctly.

Optional: Fixing the outdoor unit to a wall with a rack

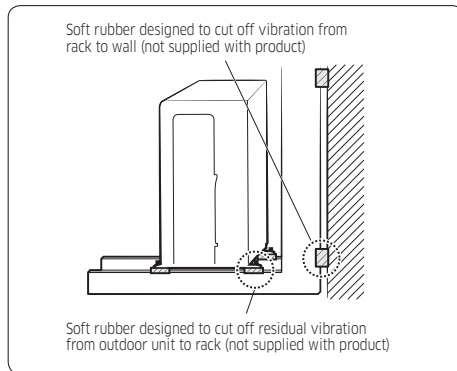

NOTE

- Make sure that the wall can support the weights of the rack and the outdoor unit.
- Install the rack close to the column as much as possible.

Step 3.2 Connecting the power and communication cables and the refrigerant pipes

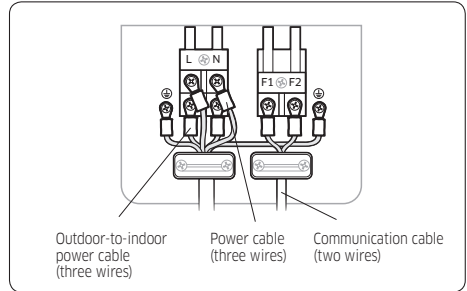

CAUTION

- Be sure to fix the power cables and communication cable with a cable clamp.

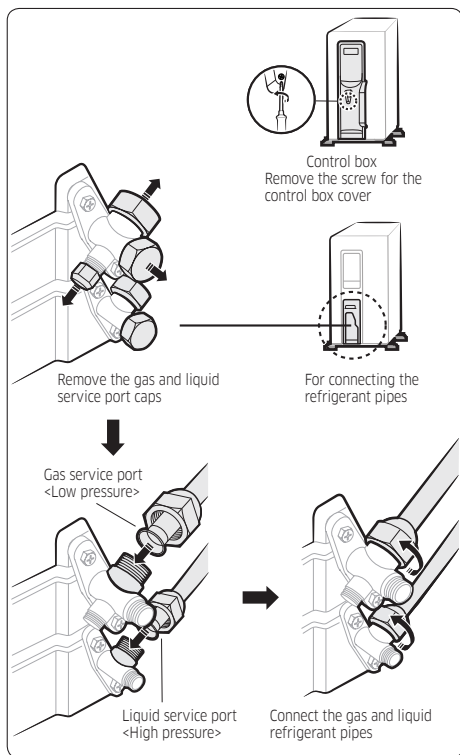

Step 3.3 Evacuating the air

The outdoor unit is loaded with sufficient R-32 refrigerant. Do not vent R-32 into atmosphere: it is a fluorinated greenhouse gas, covered by Kyoto Protocol, with a Global Warming Potential (GWP) = 675. You should evacuate the air in the indoor unit and in the pipe. If air remains in the refrigerant pipes, it affects the compressor. It may cause reduction of cooling capacity and malfunction. Use a vacuum pump.

⚠ CAUTION

- When installing, make sure there is no leakage. When recovering the refrigerant, ground the compressor first before removing the connection pipe. If the refrigerant pipe is not properly connected and the compressor works with the stop valve open, the pipe inhales the air and it makes the pressure inside of the refrigerant cycle abnormally high. It may cause explosion and injury.

1 Leave the system in the standby mode.

⚠ WARNING

- Do not turn on the system! This is necessary for better vacuum operation (full OPEN position of Electronic Expansion Valve).
- 2 Connect the charging hose of the low pressure side of manifold gauge to a gas service port as seen in the picture.

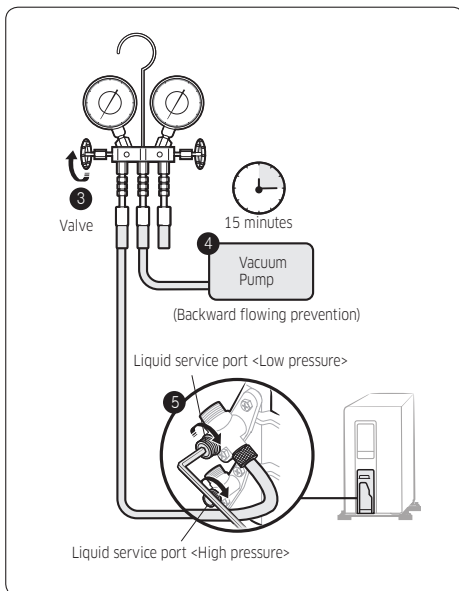

- 3 Open the valve of the low pressure side of manifold gauge anticlockwise.
- 4 Evacuate the air in the connected pipes using the vacuum pump for about 15 minutes.
 - Make sure that pressure gauge shows -0.1 MPa (-76 cmHg, 5 torr) after about 10 minutes. This procedure is very important to avoid a gas leak.
 - Close the valve of the low pressure side of manifold gauge clockwise.
 - Turn off the vacuum pump.
 - Check for 2 minutes if there is any pressure change.
 - Remove the hose of the low pressure side of manifold gauge.
- 5 Set a valve cork of liquid and gas service port to the open position.

Step 3.4 Adding refrigerant

If you use a pipe longer than 5 m, you must add 15 g of refrigerant R-32 for each extra meter. If you use a pipe shorter than 5 m, the evacuating time is normal. Refer to the Service Manual for further details.

CAUTION

- The remaining air in the Refrigeration cycle, which contains moisture, may cause malfunction on the compressor.
- Always contact the service centre or a professional installation agency for product installation.

Precautions on adding the R-32 refrigerant

In addition to the conventional charging procedure, the following requirements shall be kept.

- Make sure that contamination by other refrigerants does not occur for charging.
- To minimize the amount of refrigerant, keep the hoses and lines as short as possible.
- The cylinders shall be kept upright.
- Make sure that the refrigeration system is earthed before charging.
- Label the system after charging, if necessary.
- Extreme care is required not to overcharge the system.
- Before recharging, the pressure shall be checked with nitrogen blowing.
- After charging, check for leakage before commissioning.
- Be sure to check for leakage before leaving the work area.

Step 3.5 Important information: regulation regarding the refrigerant used

This product contains fluorinated greenhouse gases. Do not vent gases into the atmosphere.

CAUTION

- Inform user if the system contains 5 tCO₂e or more of fluorinated greenhouse gases. In this case, it must be checked for leakage at least once every 12 months, according to regulation No. 517/2014. This activity must be covered by qualified personnel only. In the case of the situation above, the installer (or authorized person with responsibility for final check) must provide a maintenance book, with all the information recorded, according to REGULATION (EU) No. 517/2014 OF THE EUROPEAN PARLIAMENT AND OF THE COUNCIL of 16 April 2014 on fluorinated greenhouse gases.
- 1 Please fill in the following with indelible ink on the refrigerant charge label supplied with this product and on this manual.
 -  the factory refrigerant charge of the product,

- ② the additional refrigerant amount charged in the field and
- ①+② the total refrigerant charge, on the refrigerant charge label supplied with the product.

Refrigerant type	GWP value
R-32	675
<ul style="list-style-type: none"> • GWP: Global Warming Potential • Calculating tCO₂e: kg x GWP/1000 	

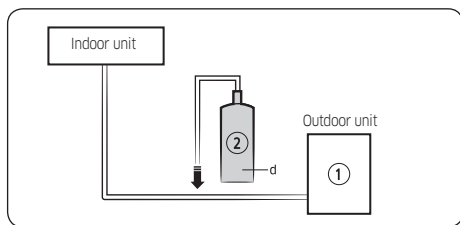

Unit	Kg	tCO ₂ e
①, a		
②, b		
①+②, c		

NOTE

- Factory refrigerant charge of the product: see unit name plate
- Additional refrigerant amount charged in the field (Refer to the above information for the quantity of refrigerant replenishment.)
- Total refrigerant charge
- Refrigerant cylinder and manifold for charging

CAUTION

- The filled-out label must be adhered in the proximity of the product charging port (e.g. onto the inside of the stop valve cover).

- Make sure that the total refrigerant charge does not exceed (A), the maximum refrigerant charge, which is calculated in the following formula:
Maximum refrigerant charge (A) = factory refrigerant charge (B) + maximum additional refrigerant charge due to piping extension (C)

Here below, the summary table with refrigerant charge limits for each products.

(Unit:g)

Model	A	B	C
09/12***	1070	920	150

Installation Inspection

Step 4.1 Performing the gas leak tests

- 1 Before inspecting the leakage, use a torque wrench to close the cap for the stop valve. (Comply with a tightening torque for each size of the diameter, and tighten the cap firmly to prevent any leakage.)

Tightening torque for charging port cap (Refer to the table)

Outer diameter (mm)	Tightening torque	
	Body cap (N•m)	Charging port cap (N•m)
ø 6.35	20 to 25	10 to 12
ø 9.52	20 to 25	
ø 12.70	25 to 30	
ø 15.88	30 to 35	
Over ø 19.05	35 to 40	

(1 N•m = 10 kgf•cm)

- 2 Insert inert gas into the pipes connected to indoor and outdoor units.
- 3 Test leakage on the connection parts of the indoor and outdoor units with soap lather or liquid.

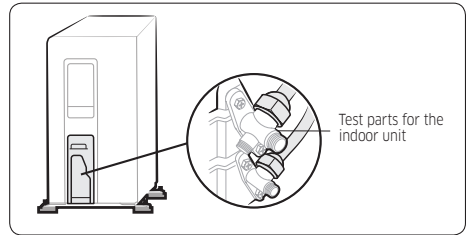
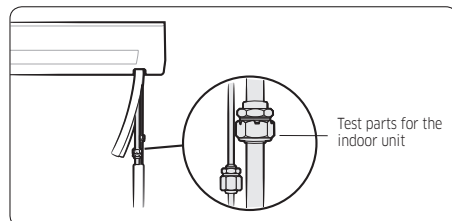

Step 4.2 Running the Smart Install mode

- 1 Make sure that the air conditioner is in the standby status.
- 2 Hold down the (Power), (Mode), and (SET) buttons on the remote control simultaneously for 4 seconds.
- 3 Wait until Smart Install mode succeeds or fails. It takes approximately 7 to 13 minutes.
 - While Smart Install mode is proceeding:



Type	Display	LED Display
Indoor unit indicator		
	The progress is displayed as a number between 0 and 99 on the indoor unit display.	The LEDs on the indoor unit display blink in sequence, then all of them blink simultaneously. These operations repeat.

- When Smart Install mode succeeds: Smart Install mode ends with ringing sound, and the air conditioner is in standby status.
- When Smart Install mode fails: An error message is displayed on the indoor unit display, and Smart Install mode ends.

NOTE





- Smart Install mode can be operated only with the supplied remote control.
- During the Smart install mode procedure, remote control cannot be operated.

When error occurs, take necessary measures by referring to the following table. For more information on necessary measures for errors, refer to the service manual.

Error indicator				Error	Measures for the installer to take
88 Display	LED Display				
	LED 1	LED 2	LED 3		
					
E 10 1	○	◐	◐	Communication error between indoor and outdoor units	<ul style="list-style-type: none"> Check the connection wire between the indoor and outdoor units (whether the power cable or communication cable is crossed or not).
E 12 1	○	◐	○	Error on indoor temperature sensor	<ul style="list-style-type: none"> Check the connection of the connector.
E 122 E 123	◐	◐	○	Error on indoor heat exchanger	<ul style="list-style-type: none"> Check the connection of the connector.
E 154	○	○	◐	Error on indoor fan motor	<ul style="list-style-type: none"> Check the connection of the connector. Remove foreign substance. (Check for the cause that restrains motor.)
88 display and all LEDs blink.	◐	◐	◐	EEPROM/Option error	<ul style="list-style-type: none"> Re-set options.
E 162 E 163					
E 422	●	○	◐	Refrigerant flow blocking error	<ul style="list-style-type: none"> Check if the stop valve is completely open. Check if there is any blockage in the refrigerant pipe which connects the indoor and outdoor units. Check for refrigerant leak.
E 554	* This LED pattern appears when an error occurs on the outdoor unit.			Lack of refrigerant (for inverter models only)	<ul style="list-style-type: none"> Check if a sufficient amount of refrigerant is additionally charged for the pipe longer than specified in piping codes and standards. Check for refrigerant leak between valve and pipe connection.

* ○ : Off, ◐ : Blinking, ● : On

Step 4.3 Performing final check and trial operation

- 1 Check the following:
 - Strength of the installation site
 - Tightness of pipe connection to detect gas leak
 - Electric wiring connection
 - Heat-resistant insulation of the pipe
 - Drainage
 - Grounding conductor connection
 - Correct operation (Take the following steps.)
- 2 Press the  (Power) button on the remote control to check the following:
 - The indicator on the indoor unit lights up.
 - The airflow blade opens and the fan gears up for operation.
- 3 Press the  (Mode) button to select Cool or Heat mode. Then take the following sub-steps:
 - In Cool mode, use the Temperature button to set the set temperature to 16 °C.
 - In Heat mode, use the Temperature button to set the set temperature to 30 °C.
 - Check whether, approximately 3 to 5 minutes later, the outdoor unit starts, and a cool air blows out.
 - After 12 minutes of stationary condition, check the indoor unit air treatment.
- 4 Press the  (Air swing) button to check whether the airflow blades work properly.
- 5 Press the  (Power) button to stop the trial operation.

Step 4.4 Display Error and Check Method

Indoor Display Error and Check Method

Indoor	ERROR MODE			DESCRIPTION
	Outdoor			
	YEL	GRN	RED	
	○	◎	●	Normal operation
	●	●	●	Power on reset(1sec)
	○	○	○	Power off / VDD NG
dF	○	◎	●	When dF shows on the 88 segment of the Indoor unit, this means that the system is in defrost mode. Note that during this operation period, system performance will be reduced.
E101	○	○	●	Communication error (Indoor↔Outdoor)
E102	○	●	●	
E121				Indoor room temperature sensor error
E122				Evap-In temperature sensor error
E154				Fan error (Indoor)
E162				EEPROM error (Indoor)
E163				Option setting error
E203	◎	●	●	1min. Time out Communcation (Inv micom↔Main micom)
E221	◎	○	◎	Outdoor temperature sensor error
E231	◎	●	◎	Outdoor Coil temperature sensor error
E251	◎	◎	○	Discharge temperature sensor error
E416	◎	○	●	Discharge over temperature
E422	●	●	○	EEV or Valve Close error-Self diagnosis
E440/ E441	●	◎	○	Out of the Limit of the operation(Outdoor temperature)
E458	●	○	○	Fan error (Outdoor)
E461	○	◎	○	Compressor starting error
E462	●	◎	●	Compressor trip error / PFC over current
E464	○	○	◎	IPM over current (O.C)
E465	◎	●	○	Compressor V-limit error
E466	○	●	◎	DC-Link voltage under/over error
E467	●	○	●	Compressor rotation error(comp. wire missing error)
E468	◎	◎	◎	Current sensor error
E469	●	◎	◎	DC-Link voltage sensor error
E470	○	●	○	EEPROM error (Outdoor)
E471	●	○	◎	OTP error
E472	●	●	◎	AC line zero cross signal error
E474	◎	◎	●	Heat-Sink sensor error
E483	○	●	◎	H/W DC-Link over
E484	○	●	◎	PFC over load
E485	◎	◎	●	Input current sensor error
E500	◎	●	○	Heat-Sink overheat error
E554	●	●	○	Gas-Leak error
E556	◎	○	○	Capacity miss match error



Maintenance Procedures

Pumping down for removing the product

Pump-down is an operation intended to collect all the system refrigerant in the outdoor unit. This operation must be carried out before disconnecting the refrigerant tubing in order to avoid refrigerant loss to the atmosphere.

⚠ WARNING

- After installing the product, be sure to perform leak tests on the piping connections. Before pumping down refrigerant to inspect or relocate the outdoor unit, be sure to stop the compressor and then remove the connected pipes.
 - Do not operate the compressor while a valve is open due to refrigerant leakage from a pipe or an unconnected or incorrectly connected pipe. Failure to do so may cause air to flow into the compressor and too a high pressure to develop inside the refrigerant circuit, leading to an explosion or product malfunction.

- 1 Hold down the  (Power) button on the indoor unit for 5 seconds. Beep sounds immediately to indicate that the product is ready for pump down procedure.
- 2 Let the compressor run for more than 5 minutes.
- 3 Release the valve caps on High and Low pressure side.
- 4 Use L-wrench to close the valve on the high pressure side.
- 5 After approximately 1 minute, close the valve on the low pressure side.
- 6 Stop operation of the air conditioner by pressing the  (Power) button on the indoor unit or remote control.
- 7 Disconnect the pipes.

⚠ CAUTION

- Compressor damage may occur if the compressor is run at a negative suction pressure.

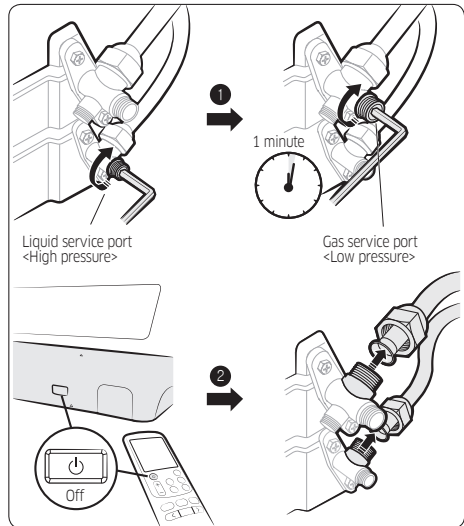

Performing the gas leak tests for repair

In case of repair of the refrigerant circuit, the following procedure must be kept to consider flammability.

1. Remove the refrigerant.
2. Purge the refrigerant circuit with inert gas.
3. Perform evacuation.
4. Purge the circuit again with inert gas.
5. Open the circuit.
6. Perform repair work.
7. Charge the system with refrigerant.
8. Flush the system with nitrogen blowing for safety.
9. Repeat the previous steps several times until no refrigerant is within the system.

⚠ CAUTION

- Compressed air or oxygen shall not be used.
- Flush the system with nitrogen blowing, fill the refrigerant until the working pressure is reached, ventilate to atmosphere, and then pull down to a vacuum state.
- For the final nitrogen blowing charge, the system shall be ventilated down to atmospheric pressure.

- The procedure is absolutely vital in case of brazing on the pipings.
- Make sure that the outlet of the vacuum pump is not closed to any ignition sources and there is ventilation available.
- Do not apply any permanent inductive or capacitance loads to the circuit without ensuring that this will not exceed the permissible voltage and current permitted for the air conditioner.

10. After charging, make sure that the cylinders and the equipment are promptly removed from the site and all isolation valves are closed.
11. Recovered refrigerant shall not be charged into other refrigeration system unless it is cleaned and checked.

Decommissioning

The following requirements must be fulfilled before and while taking the decommissioning procedure:

- Before decommissioning, the worker shall be familiar with the product details.
 - The entire refrigerant shall be recovered safely.
 - Before starting the process, oil and refrigerant samples shall be taken just in case analysis is required for reuse.
 - Before starting the process, power supply must be available.
1. Be familiar with the equipment details.
 2. Isolate the system electrically.
 3. Before starting the process, make sure that:
 - Any mechanical equipment is available for handling refrigerant cylinders.
 - All PPE (personal protective equipment) is available for servicing.
 - The recovery process shall be supervised by a competent person.
 - The recovery equipment and cylinders comply with the standards.
 4. Lower the refrigeration system, if possible.
 5. If vacuuming is not possible, make a manifold so that refrigerant can be easily removed from the parts of the system.
 6. Make sure that the cylinders are placed on the scales before recovery.
 7. Run the recovery system in accordance with the manufacturer's instructions.
 8. Do not overcharge the cylinders. (No more than 80 %)
 9. Be sure to keep the cylinder within the maximum working pressure, even temporarily.

Record of Installation:

It is recommended that your receipt be stapled to this page for proof of purchase date and/or for warranty purposes should it be required.

Please ensure that the following information is recorded once the installation has been completed:

Purchase Information:

Date of Purchase:	
Dealer Company Name	
Dealer Company Address	

Product Information (Data can be found on the product mark plates):

Outdoor	Model Code	
	Serial Number	
	Software Version	
Indoor	Model Code	
	Serial Number	
	Software Version	

Installation Information:

Date of Installation:	
Location/Address:	
Installation Company Name	
Installation Company Address	

Recommended Installation Guidance (On the behalf of the customer):

	Yes	No
Has the customer been provided guidance regarding the maintenance of the product?		
Has the customer been provided guidance regarding the operation of the product?		

In order to ensure the correct installation and operation of this product, it is recommended that a service visit be arranged within a reasonable period of time.

In the event of a service issue, please refer to the troubleshooting guide of the relevant supporting manuals. It is recommended that a skilled service technician be contacted for support. Should urgent support be required then, using the information provided, contact the local Samsung office via email or telephone so that support can be initiated via our approved service centres (ASC'S) within 24hrs.

It is also recommended that the product be registered with the manufacturer shortly after the date of installation. Please register your product at the following location:

www.samsung.com/warranty